

# Channel Assignment Strategies for Multiradio Wireless Mesh Networks: Issues and Solutions

*Habiba Skalli, IMT Lucca Institute for Advanced Studies*

*Samik Ghosh and Sajal K. Das, The University of Texas at Arlington*

*Luciano Lenzini, University of Pisa*

*Marco Conti, Italian National Research Council (CNR)*

## ABSTRACT

Next-generation wireless mobile communications will be driven by *converged networks* that integrate disparate technologies and services. The wireless mesh network is envisaged to be one of the key components in the converged networks of the future, providing flexible high-bandwidth wireless backhaul over large geographical areas. While single radio mesh nodes operating on a single channel suffer from capacity constraints, equipping mesh routers with multiple radios using multiple nonoverlapping channels can significantly alleviate the capacity problem and increase the aggregate bandwidth available to the network. However, the assignment of channels to the radio interfaces poses significant challenges. The goal of channel assignment algorithms in multiradio mesh networks is to minimize interference while improving the aggregate network capacity and maintaining the connectivity of the network. In this article we examine the unique constraints of channel assignment in wireless mesh networks and identify the key factors governing assignment schemes, with particular reference to interference, traffic patterns, and multipath connectivity. After presenting a taxonomy of existing channel assignment algorithms for WMNs, we describe a new channel assignment scheme called *MesTiC*, which incorporates the mesh traffic pattern together with connectivity issues in order to minimize interference in multiradio mesh networks.

## INTRODUCTION

The next generation of wireless communication systems are envisaged to provide high-speed, high-bandwidth ubiquitous connectivity to end users through a *converged network* of different technologies, such as third- and fourth-generation (3G/4G) mobile cellular systems, IEEE 802.11 (WiFi) based wireless local area networks

(WLANs), and emerging broadband wireless technologies such as IEEE 802.16 (WiMAX).

One of the key components of such converged networks is the wireless mesh network (WMN), which is a *fully wireless* network that employs *multihop* ad hoc networking techniques to forward traffic to/from the Internet. Unlike the mobile ad hoc network (MANET), a mesh network uses dedicated nodes (called *mesh routers*) to build a *wireless backbone* to provide multihop connectivity between nomadic users and the Internet gateways [1]. WMNs can provide significant advantages in deploying cost-efficient, highly flexible, and reconfigurable backhaul connectivity over large areas. As highlighted in [2], WMNs have emerged as a promising candidate for extending the coverage of *WiFi islands* and providing flexible high-bandwidth wireless backhaul for converged networks.

The wireless backbone, consisting of wireless mesh routers equipped with one or more radio interfaces, highly affects the capacity of the mesh network. This has a significant impact on the overall performance of the system, thus generating extensive research in order to tackle the specific challenges of the WMN. (See [3] for a survey).

Current state-of-the-art mesh networks, which use off-the-shelf 802.11-based network cards, are typically configured to operate on a single channel using a single radio. This configuration adversely affects the capacity of the mesh due to interference from adjacent nodes in the network, as identified in [3]. Various schemes have been proposed to address this capacity problem, such as modified medium access control (MAC) protocols adapted to WMNs [4], the use of channel switching on a single radio [5, 6], and directional antennas [3]. While directional antennas and modified MAC protocols make the practical deployment of such solutions infeasible on a wide scale, the main issue in using multiple channels with a single radio is that dynamic channel switching requires tight time synchronization between the nodes.

*This work was done while the first author was visiting Center for Research in Wireless Mobility and Networking (CRW-MaN), The University of Texas at Arlington.*

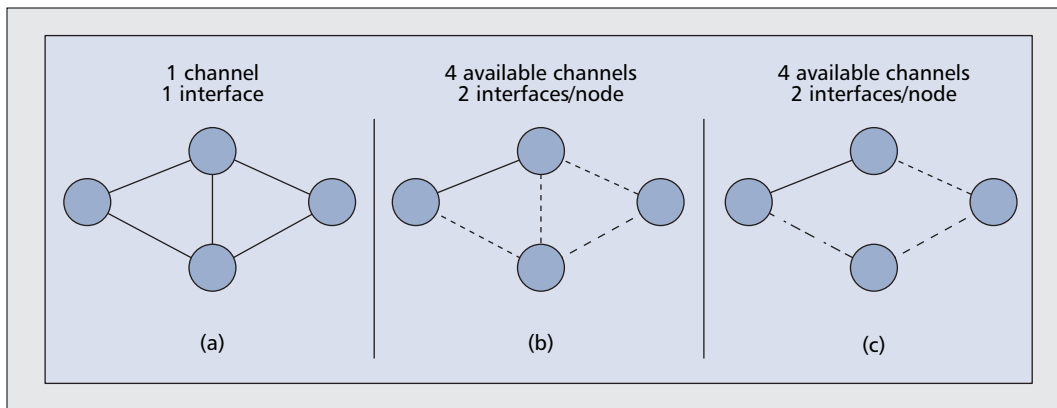

**Figure 1.** Trade-off between connectivity and interference: a) single channel scenario; b) maximum connectivity; c) minimum interference.

Equipping each node with multiple radios is emerging as a promising approach to improving the capacity of WMNs. First, the IEEE 802.11b/g and IEEE 802.11a standards provide 3 and 12 nonoverlapping (frequency) channels, respectively, which can be used simultaneously within a neighborhood (by assigning nonoverlapping channels to radios). This then leads to efficient spectrum utilization and increases the actual bandwidth available to the network. Second, the availability of cheap off-the-shelf commodity hardware also makes multiradio solutions economically attractive. Finally, the spatio-temporal diversity of radios operating on different frequencies with different sensing-to-hearing ranges, bandwidth, and fading characteristics can be leveraged to improve the capacity of the network.

Although multiradio mesh nodes have the potential to significantly improve the performance of mesh networks, efficient channel assignment is a key issue in guaranteeing network connectivity while still mitigating the adverse effects of interference from the limited number of channels available to the network. A WMN node needs to share a common channel with each of its communication-range neighbors with which it wishes to set up a *virtual link*<sup>1</sup> or connectivity. However, to reduce interference, a node should minimize the number of neighbors with which it will share a common channel. There is thus a trade-off between maximizing connectivity and minimizing interference, as illustrated in Fig. 1. In this figure the maximum connectivity that can be achieved is shown in Fig. 1a. In both Fig. 1b and 1c, there are four channels available but only three can be assigned to the radios in Fig. 1b that maximize connectivity. On the other hand, all four can be exploited simultaneously if the only goal is to minimize interference, as shown in Fig. 1c.

The above issues provided us with the motivation to undertake a systematic study of different channel assignment schemes for WMNs, and examine their relative strengths and weaknesses, as outlined later. Based on our research, we identify the key characteristics pertinent to channel assignment in WMNs and present an innovative scheme called *MesTiC* for channel assignment in multiradio mesh networks. *MesTiC* is a static centralized channel assignment scheme based on a ranking function that takes into

account traffic, number of hops from the gateway, and number of radio interfaces per node. We summarize the performance of *MesTiC* in terms of network throughput on a comparative simulation platform. We compare the different CA schemes. We then conclude the article.

## A TAXONOMY OF CHANNEL ASSIGNMENT SCHEMES FOR WMNs

Channel assignment (CA) in a multiradio WMN environment consists of assigning channels to the radio interfaces in order to achieve efficient channel utilization and minimize interference. The problem of optimally assigning channels in an arbitrary mesh topology has been proven to be NP-hard based on its mapping to a *graph-coloring* problem [7]. Therefore, channel assignment schemes predominantly employ heuristic techniques to assign channels to nodes in the network. The performance bottleneck associated with channel assignment in WMNs has been extensively studied in the literature. In this section we present a taxonomical classification of various CA schemes for mesh networks. Figure 2 presents the taxonomy on which the rest of the section is based. Specifically, the proposed CA schemes can be divided into three main categories — fixed, dynamic, and hybrid — depending on the frequency with which the CA scheme is modified. In a fixed scheme the CA is almost constant, while in a dynamic scheme it is continuously updated to improve performance. A hybrid scheme applies a fixed scheme for some interfaces and a dynamic one for others. In the following we analyze these three categories and give examples of CA schemes from each category.

### FIXED CHANNEL ASSIGNMENT SCHEMES

Fixed assignment schemes assign channels to interfaces either permanently or for long time intervals with respect to the interface switching time. Such schemes can be further subdivided into common channel assignment and varying channel assignment.

**Common Channel Assignment** — This is the simplest scheme. In CCA [8] the radio interfaces of each node are all assigned the same set of channels. The main benefit is that the connectiv-

In a fixed scheme the CA is almost constant, while in a dynamic scheme it is continuously updated to improve performance. A hybrid scheme applies a fixed scheme for some interfaces and a dynamic one for others.

<sup>1</sup> A virtual link between two nodes is defined as a possible direct communication link between them.

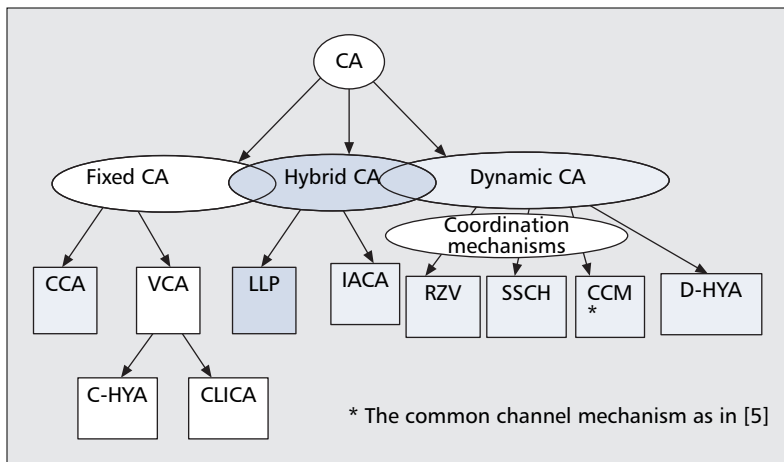

■ **Figure 2.** Taxonomy of channel assignment schemes in wireless mesh networks.

ity of the network is the same as that of a single-channel approach, while the use of multiple channels increases network throughput. However, the gain may be limited in scenarios where the number of nonoverlapping channels is much greater than the number of network interface cards (NICs)<sup>2</sup> used per node. Thus, although this scheme presents a simple CA strategy, it fails to account for the various factors affecting channel assignment in a WMN.

**Varying Channel Assignment** — In the VCA scheme, interfaces of different nodes may be assigned different sets of channels [7, 9]. However, the assignment of channels may lead to network partitions and topology changes that may increase the length of routes between the mesh nodes. Therefore, in this scheme, assignment needs to be carried out carefully. Below we present the VCA approach through two existing algorithms in this subcategory.

**Centralized Channel Assignment** — Based on *Hyacinth*, a multichannel wireless mesh network architecture, a centralized channel assignment algorithm for WMNs (C-HYA) is proposed in [7], where traffic is mainly directed toward gateway nodes (i.e. the traffic is directed to/from the Internet). Assuming the traffic load is known, this algorithm assigns channels, thus ensuring the network connectivity and bandwidth limitations of each link. It first estimates the total expected load on each virtual link based on the load imposed by each traffic flow. Then the channel assignment algorithm visits each virtual link in decreasing order of expected traffic loads and greedily assigns it a channel. The algorithm starts with an initial estimation of the expected traffic load and iterates over both channel assignment and routing until the bandwidth allocated to each virtual link matches its expected load. While this scheme presents a method for channel allocation that incorporates connectivity and traffic patterns, the assignment of channels on links may cause a *ripple effect* [7] whereby already assigned links have to be revisited, thus increasing the time complexity of the scheme.

<sup>2</sup> Note: In this article we use NIC and radio interface interchangeably.

**A Topology Control Approach** — In [9] the notion of a traffic independent channel assignment scheme is proposed to enable an efficient and flexible topology formation, ease of coordination, and to exploit the static nature of mesh routers to update the channel assignment on large timescales. A polynomial time greedy heuristic called Connected Low Interference Channel Assignment (CLICA) is presented in [9] that computes the priority for each mesh node and assigns channels based on the connectivity graph and conflict graph. However, the algorithm can override the priority of a node to account for the lack of flexibility in terms of channel assignment and to ensure network connectivity. Thus, while this scheme overcomes link revisits, it does not incorporate the role of traffic patterns in channel assignment for WMNs.

#### DYNAMIC CHANNEL ASSIGNMENT SCHEMES

Dynamic assignment strategies allow any interface to be assigned any channel, and interfaces can frequently switch from one channel to another. Therefore, when nodes need to communicate with each other, a coordination mechanism has to ensure they are on a common channel. For example, such mechanisms may require all nodes to periodically visit a predetermined *rendezvous* channel [5] to negotiate channels for the next phase of transmission. In the Slotted Seeded Channel Hopping (SSCH) mechanism [6], each node switches channels synchronously in a pseudo-random sequence so that all neighbors meet periodically in the same channel.

The benefit of dynamic assignment is the ability to switch an interface to any channel, thereby offering the potential to use many channels with few interfaces. However, the key challenges involve channel switching delays (typically on the order of milliseconds in commodity 802.11 wireless cards), and the need for coordination mechanisms for channel switching between nodes.

**A Distributed Channel Assignment Scheme** — A set of dynamic and distributed channel assignment algorithms is proposed in [10, 11], which can react to traffic load changes in order to improve the aggregate throughput and achieve load balancing. Based on the *Hyacinth* architecture, the algorithm (D-HYA) builds on a spanning tree network topology in such a way that each gateway node (the node directly connected to the wired network) is the root of a spanning tree, and every mesh node belongs to one of these trees. The channel assignment problem consists of:

- *Neighbor-to-interface binding* (i.e., it selects the interface to communicate with every neighbor), where the dependence among the nodes is eliminated in order to prevent *ripple effects* in the network [7]
- *Interface-to-channel binding* (i.e., it selects the channel to assign to every interface), where the goal is to balance the load among the nodes and relieve interference

Finally, channels are dynamically assigned to the interfaces based on their traffic information. The tree-topology constraint of the scheme poses a potential hindrance in leveraging multipath routing in mesh networks.

## HYBRID CHANNEL ASSIGNMENT SCHEMES

Hybrid channel assignment strategies combine both static and dynamic assignment properties by applying a fixed assignment for some interfaces and a dynamic assignment for other interfaces [8, 12, 13]. Hybrid strategies can be further classified based on whether the fixed interfaces use a common channel [13] or varying channel [8, 12] approach. The fixed interfaces can be assigned a dedicated control channel [10] or a data and control channel [13], while the other interfaces can be switched dynamically among channels. Hybrid assignment strategies are attractive because, as with fixed assignment, they allow for simple coordination algorithms, while still retaining the flexibility of dynamic channel assignment.

In the next two subsections we describe two hybrid schemes for CA.

### **Link Layer Protocols for Interface Assignment**

— In [8, 12] an innovative link layer interface assignment algorithm (LLP) is proposed that categorizes available interfaces into fixed and switchable interfaces. Fixed interfaces are assigned, for long time intervals, specific fixed channels, which can be different for different nodes. On the other hand, switchable interfaces can be switched over short timescales among non-fixed channels based on the amount of data traffic. By distributing fixed interfaces of different nodes on different channels, all channels can be used, while the switchable interface can be used to maintain connectivity. Two coordination protocols based on hash functions and the exchange of Hello packets are proposed in [8] to decide which channels should be assigned to the fixed interface and manage communication between nodes. In [12] the authors propose a CA scheme based on the second coordination protocol, but this scheme does not take into account the traffic load in assigning the fixed channels.

### **Interference-Aware Channel Assignment**

— The channel assignment problem in wireless mesh networks in the presence of interference from collocated wireless networks is addressed in [13]. The authors propose a dynamic centralized interference-aware algorithm (IACA) aimed at improving the capacity of the WMN backbone and minimizing interference. This algorithm is based on an extension to the conflict graph concept described in [9], called the multiradio conflict graph (MCG), where the vertices in the MCG represent edges between mesh radios instead of edges between mesh routers. To compensate for the drawbacks of a dynamic network topology, the proposed solution assigns one radio on each node to operate on a default common channel throughout the network. This strategy ensures a common network connectivity graph [13], provides alternate fallback routes, and avoids flow disruption by traffic redirection over a default channel. This scheme computes interference and bandwidth estimates based on the number of interfering radios, where an *interfering radio* is a simultaneously operating radio that is *visible* to a mesh

router but external to its network. The channel assignment scheme works on a rank-based strategy where the rank for every available channel is based on interference and load. The load, however, is considered for external wireless networks only.

## MESTiC: A NEW CHANNEL ASSIGNMENT SCHEME

As highlighted earlier, the central goal of channel assignment for multiradio mesh networks is to improve the aggregate throughput of the network, taking into account the effects of traffic and interference patterns, as well as maintaining topological connectivity. Based on our observations of the impact of traffic patterns and network connectivity on the performance of a WMN, below we propose an innovative scheme called *MesTiC*, which stands for mesh-based traffic and interference aware channel assignment. It has the following important features:

- *MesTiC* is a fixed, rank-based, polynomial time greedy algorithm for centralized channel assignment, which visits every node once, thereby mitigating any ripple effect.
- The *rank* of each node is computed on the basis of its link traffic characteristics, topological properties, and number of NICs on a node.
- Topological connectivity is ensured by a common default channel deployed on a separate radio on each node, which can also be used for network management.

Fixed schemes alleviate the need for channel switching, especially when switching delays are large as is the case with the current 802.11 hardware. In addition, *MesTiC* is rank-based, which gives the nodes that are expected to carry heavy loads more flexibility in assigning channels. Finally, the use of a common default channel prevents flow disruption.

It should also be mentioned that the proposed scheme has been designed for a mesh network with a single gateway node, but could easily be extended to multiple gateways with minor modifications to the basic scheme.

### PROPOSED ALGORITHM

The central idea behind *MesTiC* is to assign channels to the radios of a mesh node based on ranks assigned a priori to the nodes. The rank of a node,  $Rank(node)$ , determines its priority in assigning channels to the links emanating from it. The rank encompasses the dynamics of channel assignment and is computed on the basis of three factors:

- The aggregate traffic at a node based on the offered load of the mesh network as computed in [7]
- The distance of the node, measured as the minimum number of hops from the gateway node
- The number of radio interfaces available on a node

Note that the gateway node is assigned the highest rank as it is expected to carry the most traffic. The rank for the remaining nodes is given by:

The channel assignment scheme works on a rank-based strategy where the rank for every available channel is based on interference and load. The load, however, is considered for external wireless networks only.



$$Rank(node) = \frac{Aggregate\ Traffic(node)}{\min\ hops\ from\ the\ gateway\ (node) * number\ of\ radios\ (node)} \quad (1)$$

Clearly, the aggregate traffic flowing through a mesh node has an impact on the channel assignment strategy. The rationale behind this observation stems from the fact that if a node relays more traffic, assigning it a channel of least interference will increase the network throughput. Thus, aggregate traffic in the numerator in Eq. 1 increases the rank of a node with its traffic. In addition, due to the hierarchical nature of a mesh topology, the nodes nearest the gateway should have a higher preference (rank) in channel assignment, as they are more

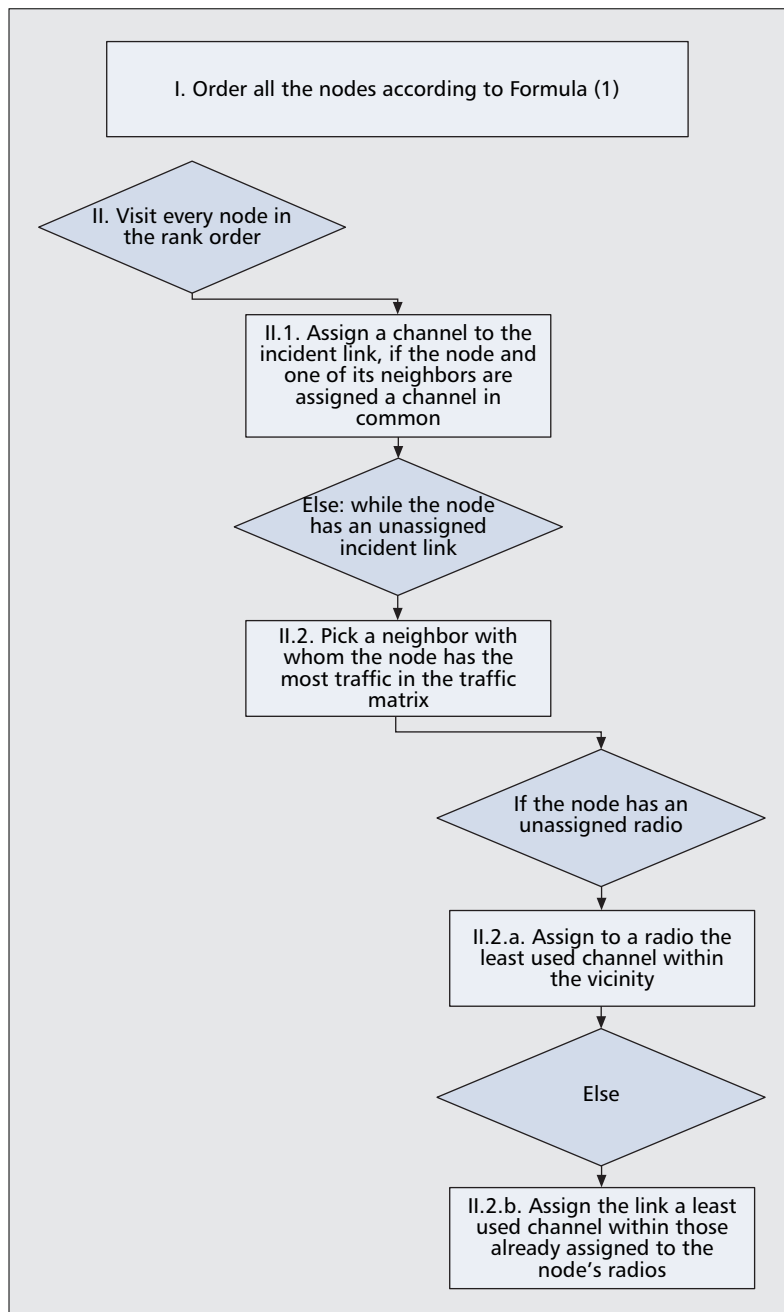

■ Figure 3. Flow diagram of MesTiC.

likely to carry more traffic. At the same time, the number of radios on a node gives flexibility in channel assignments and should inversely affect its priority (i.e., the lower the number of radios, the higher the priority in channel assignment). The aggregate traffic (total traffic traversing a node) is a key factor in computing the rank of the node. Such measure is subject to temporal variability due to the randomness of the wireless channel, routing protocols and application layer traffic profiles. We envisage that the traffic characterizations aggregated from a large number of network flows change over longer periods of time, whereas *MesTiC* can reassign channels based on new traffic characteristics.

Once the rank of each node has been computed, the algorithm traverses the mesh network in decreasing order of  $Rank(node)$ , assigning channels to the radios as described in Fig. 3. In this figure the algorithm starts by calculating a fixed rank for every node (I), and then every node is visited in decreasing order (II). If two nodes have already been assigned at least one common channel, by default there is a link between these nodes (II.1). If not, for every possible unassigned link, the one that carries the higher traffic is assigned first (II.2) in the following manner: if the node visited still has an assigned radio, the least used channel is assigned to one of its free radios and a link is established with its neighbor (II.2.a). Otherwise, if all the visited node's radios have already been assigned, the least used channel among those already assigned to its radios is assigned to the link (II.2.b). For a detailed description of the *MesTiC* algorithm, please refer to [14].

We illustrate the working principle of *MesTiC* by considering a simple example in Fig. 4a where the input connectivity graph and estimated link traffic (estimated traffic between a node and its neighbors) are shown. In addition the network is configured with three channels and two interfaces per node. Assuming that node **b** is the gateway node, the rank of the remaining nodes, in decreasing order, is **d**, **a**, **c**. The algorithm starts by visiting node **b** first, assigning channel **C1** to the link between **b-a** (which carries the highest traffic of 120), and then moving on to assign channel **C2** to link **b-d**. Now, while assigning a channel to link **b-c**, it has to choose between **C1** and **C2**. However, as **C1** carries more traffic than **C2**, it assigns **C2** to link **b-c**. Similarly, at node **d**, it assigns a previously unassigned channel **C3** to link **d-c**, and as **C3** carries less traffic than **C2** ( $90 + 80 = 170$ ) or **C1** (120), it assigns **C3** to link **d-a**. The algorithm proceeds until all links and radios are assigned channels, as shown in Fig. 4b.

In this manner *MesTiC* assigns channels to the radio interfaces of the nodes in a WMN, while the connectivity of the network is ensured through a separate radio on a default channel. The cost dynamics of 802.11-based hardware and the availability of 12 nonoverlapping channels in the IEEE 802.11a standard make a default connectivity scheme feasible under current scenarios for community mesh networks.

## PERFORMANCE STUDY

In this section we study the performance of the proposed channel assignment scheme, *MesTiC*, in terms of overall throughput on a wireless mesh network. We present details of the simulation platform and results of a comparison with the traffic-aware centralized scheme based on the *Hyacinth architecture* [7], C-HYA.

In order to build a common platform for a comparative study, we developed our simulation on a modified version of ns-2 [15] software, which incorporates support for multiple radios and configurable routing protocols, such as dynamic source routing (DSR) and ad hoc on demand distance vector routing (AODV). The simulation experiments were performed on a  $5 \times 5$  grid topology<sup>3</sup> where each node could potentially communicate with four neighbors. With a randomly generated traffic profile, the traffic between any source-destination pair is chosen in the range [0–3] Mb/s. ns-2 was configured to emulate the traffic profile by running constant bit rate (CBR) UDP flows. The conflict graph was created based on the interference-to-communication ratio set to 2, and the experiments reported in this article were performed based on the DSR protocol. As mentioned earlier, the centralized CA scheme based on C-HYA accounts for the link traffic matrix in their channel assignment algorithm. Moreover, their simulation analysis is based on a similar ns-2-based platform with similar settings. Thus, in this article we report our results based on comparisons with C-HYA. However, our simulation platform can easily be extended to incorporate different routing and channel assignment schemes for mesh networks.

The WMN was simulated on ns-2 with the number of radios on each node set to 3, with 12 nonoverlapping channels. The simulation was performed for 100 s for a given set of traffic profiles, and ns-2 was configured to report the aggregate throughput obtained in the network. The experiments were conducted on the mesh network topology with channel assignments generated by *MesTiC*, and repeated for the channel assignments generated by C-HYA. Figure 5 reports the dynamics of the network in terms of aggregate throughput. The figure highlights that the simulation stabilizes around 40 s from the start of the simulation run, after which *MesTiC* reports a sustained higher aggregate throughput for the mesh network.

Similarly, at the stable region, with *MesTiC* there is enough bandwidth for a larger number of flows in the system, with an average value of 14 flows against an average of 9 flows in C-HYA [14]. Our extensive simulation results (not reported due to space constraints) conclude that *MesTiC* provides a significant improvement in aggregate throughput over C-HYA for various topologies and traffic profiles [14].

Note that although the simulation experiments were performed with three radios per node, *MesTiC* essentially operates its channel assignment scheme on two radios, with the third configured on a default channel for connectivity. Thus, even with a lower degree of freedom in terms of radio flexibility, *MesTiC* was able to

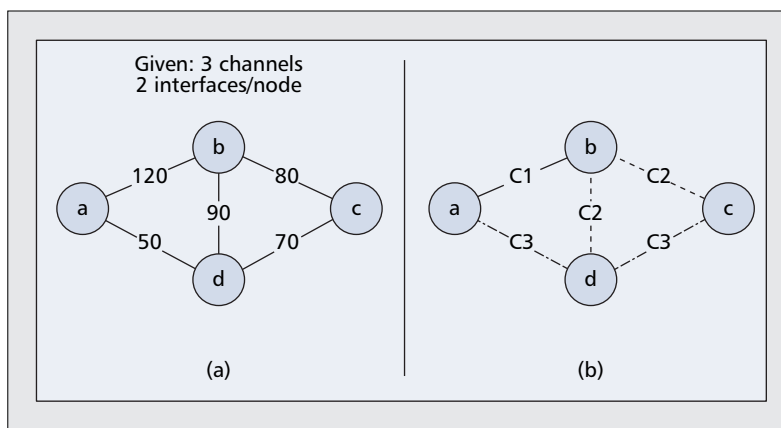

■ **Figure 4.** Example illustrating how *MesTiC* works: a) connectivity and link traffic; b) channel assignment with *MesTiC*.

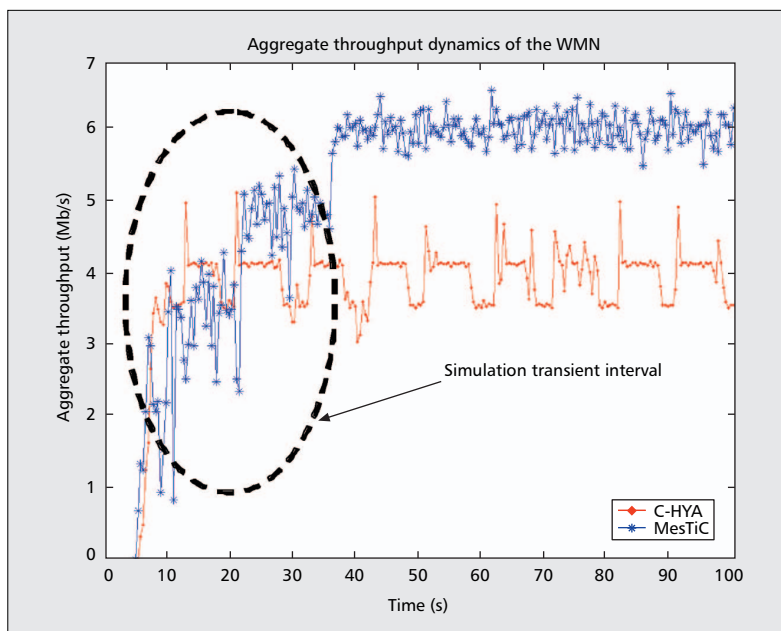

■ **Figure 5.** Aggregate throughput dynamics of *MesTiC* vs. C-HYA.

improve the overall network performance in terms of aggregate throughput.

## COMPARISON OF CA SCHEMES

The most important features of the existing CA algorithms for WMNs are summarized in Table 1.

The key issues are connectivity, topology control, interference minimization, and traffic pattern. C-HYA is a traffic-aware CA scheme. While its distributed version, D-HYA, alleviates the effect of link revisits, stringent restrictions were imposed on the topology of the mesh network, thereby failing to leverage the advantages of multipath routing in a mesh scenario. While the goal of LLP and CLICA was to minimize interference, the effect of traffic patterns on interference and thus on the CA scheme was not taken into account. The effect of traffic in IACA was considered, but only for traffic emanating from external wireless networks. From another

<sup>3</sup> Although simulations can be conducted on larger networks, we report on a 25-node mesh network, as community mesh networks are envisaged to contain typically 25–30 mesh routers.

Property	Fixed CA				Hybrid CA		Dynamic CA
	CCA	C-HYA [7]	CLICA [9]	MesTiC	LLP [8]	IACA [10]	D-HYA [6]
Switching time	No switching required	No switching required	No switching required	No switching required	Switching overhead involved	Infrequent switching	Infrequent switching
Connectivity	Ensured by the CA scheme	Ensured by the CA scheme	Ensured by the CA scheme	Ensured by default radio	Ensured by channel switching	Ensured by default radio	Ensured by the CA scheme
Ripple effect	No	Yes	No	No	No	No	No
Interference model	N/A	Protocol model	Protocol model	Protocol model	Protocol model	Trace driven	Trace driven
Traffic pattern	Not considered	Considered	Not considered	Considered	Not considered	Considered from external radios	Considered
Topology control	Fixed	Fixed	CA scheme defines the topology	Fixed	Dynamically changing	Fixed	No, topology is defined by the routing tree
Control philosophy	N/A	Centralized	Centralized	Centralized	Distributed	Centralized	Distributed

■ **Table 1.** Comparative study of the salient features of channel assignment schemes.

perspective, some algorithms, such as CLICA, considered topology control, which incurs overheads in the channel assignment algorithm but alleviates the need for an additional interface tuned to a common channel; while others (e.g. IACA) assume default connectivity using a separate common channel on a separate radio.

*MesTiC* is a fixed centralized scheme that takes into account traffic load information while assigning channels to radio interfaces. This is important because links that need to support higher traffic should be given more bandwidth. This means that these links should use a frequency channel shared by a fewer number of nodes. Although C-HYA and D-HYA both consider traffic load, they suffer from ripple effects and topology constraints, respectively. Moreover, *MesTiC* uses a default radio that creates a fixed topology and alleviates the need for a mechanism to ensure connectivity, as is the case for CLICA.

## CONCLUSIONS

In this article we have identified the key challenges associated with assigning channels to radio interfaces in a multiradio WMN. After presenting a taxonomy of existing channel assignment schemes, we describe an innovative algorithm, *MesTiC*, which incorporates traffic patterns and network topology while ranking nodes for channel assignments. Since the problem of defining optimal routes in a mesh network is closely linked to channel assignment schemes, we are currently studying the impact of channel assignment schemes on the performance of routing protocols for wireless mesh networks.

## REFERENCES

- [1] R. Bruno, M. Conti, and E. Gregori, "Mesh Networks: Commodity Multi-hop Ad Hoc Networks," *IEEE Commun. Mag.*, Mar. 2005, pp. 123–31.
- [2] R. Karrer, A. Sabharwal and E. Knightly, "Enabling Large-scale Wireless Broadband: The Case for TAPs," *2nd Wksp. Hot Topics in Wireless*, Nov. 2003.
- [3] I. Akyildiz, X. Wang, and W. Wang, "Wireless Mesh Networks: A Survey," *Comp. Networks*, vol. 47, no. 47, 2005, pp. 445–87.
- [4] X. Wang, W. Wang, and M. Nova, "A High Performance Single-Channel IEEE 802.11 MAC with Distributed TDMA," Tech. rep., Kiyon, Inc. (submitted for patent application), Oct. 2004.
- [5] J. So and N. Vaidya, "Multi-Channel MAC for Ad Hoc Networks: Handling Multi-Channel Hidden Terminals using a Single Transceiver," *Proc. ACM Mobihoc*, 2004, pp. 222–33.
- [6] P. Bahl, R. Chandra and J. Dunagan, "SSCH: Slotted Seeded Channel Hopping for Capacity Improvement in IEEE 802.11 Ad-Hoc Wireless Networks," *Proc. ACM Mobicom*, 2004, pp. 216–30.
- [7] A. Raniwala, K. Gopalan, and T. Chiueh, "Centralized Channel Assignment and Routing Algorithms for Multi-channel Wireless Mesh Networks," *ACM Mobile Comp. and Commun. Rev.*, Apr. 2004, pp. 50–65.
- [8] P. Kyasanur and N. Vaidya, "Routing and Interface Assignment in Multi-Channel Multi-Interface Wireless Networks," *Proc. IEEE Conf. Wireless Commun. and Net. Conf.*, 2005, pp. 2051–56.
- [9] M. Marina and S. R. Das, "A Topology Control Approach for Utilizing Multiple Channels in Multi-Radio Wireless Mesh Networks," *Proc. Broadnets*, Oct 2005, pp. 381–90.
- [10] A. Raniwala and T. Chiueh, "Evaluation of a Wireless Enterprise Backbone Network Architecture," *Proc. 12th Hot-Interconnects*, 2004.
- [11] A. Raniwala, and T. Chiueh, "Architecture and Algorithms for an IEEE 802.11-Based Multi-Channel Wireless Mesh Network," *Proc. IEEE INFOCOM*, Mar 2005, pp. 2223–34.
- [12] P. Kyasanur and N. Vaidya, "Routing and Link-layer Protocols for Multi-Channel Multi-Interface Ad Hoc Wireless Networks," *Mobile Comp. and Commun. Rev.*, vol. 10, no. 1, Jan. 2006, pp. 31–43.
- [13] K. Ramachandran *et al.*, "Interference Aware Channel Assignment in Multi-Radio Wireless Mesh Networks," *Proc. IEEE INFOCOM*, Apr. 2006.

- [14] H. Skalli *et al.*, "Traffic and Interference Aware Channel Assignment for Multiradio Wireless Mesh Networks," Tech. rep., Dec. 2006, [http://www.imtlucca.it/\\_documents/publications/publication54-9369-Technical\\_report\\_2006.pdf](http://www.imtlucca.it/_documents/publications/publication54-9369-Technical_report_2006.pdf)
- [15] Network Simulator ns-2, <http://www.isi.edu/nsnam/ns/>

## BIOGRAPHIES

HABIBA SKALLI ([habiba.skalli@imtlucca.it](mailto:habiba.skalli@imtlucca.it)) received her Master (2004) and Bachelor (2003) degrees in computer science and engineering from Al Akhawayn University, Ifrane, Morocco. She is now a Ph.D. student at IMT — Lucca Institute (Italy) under the supervision of Prof. Luciano Lenzini (University of Pisa, Italy) and Dr. Marco Conti (IIT/CNR Pisa, Italy). During her Ph.D. she spent a visiting period at the Center for Research in Wireless Mobility and Networking (CRWMan) at the University of Texas at Arlington and did research under Prof. Sajal Das. Her current research interests are in channel assignment and routing algorithms for wireless mesh networks.

SAMIK GHOSH ([sghosh@cse.uta.edu](mailto:sghosh@cse.uta.edu)) received a Bachelor of Technology (Honors) degree in computer science and engineering from Haldia Institute of Technology, India, in 2001. After working in the telecommunication software industry for a year, he began his graduate studies at CRWMan, Department of Computer Science and Engineering, the University of Texas at Arlington, where he is currently a second year doctoral student. His research interests lie in mobile communications, wireless mesh networks, and developing mobile applications for handheld devices. He also works in modeling and simulation of complex systems in life sciences.

SAJAL K. DAS ([das@cse.uta.edu](mailto:das@cse.uta.edu)) is a Distinguished Scholar Professor of Computer Science and Engineering and also the founding director of CRWMan at the University of Texas at Arlington. His current research interests include sensor networks, smart environments, resource and mobility management in wireless networks, mobile and pervasive computing, wireless mesh networks, grid computing, biological networking, applied graph theory, and game theory. He coauthored the book *Smart Environments: Technology, Protocols, and Applications* (Wiley, 2005). He has published over 400 research papers in international

conferences and journals, and holds five U.S. patents. He received Best Paper Awards at IEEE PerCom '06, ACM MobiCom '99, ICOIN '02, ACM MSWiM '00, and ACM/IEEE PADS '97. He is also a recipient of UTA Outstanding Faculty Research Award in Computer Science (2001 and 2003), College of Engineering Research Excellence Award (2003), University Award for Distinguished record of Research (2005), and UTA Academy of Distinguished Scholars Award (2006). He serves as Editor-in-Chief of *Pervasive and Mobile Computing*, and Associate Editor of *IEEE Transactions on Mobile Computing*, *ACM/Springer Wireless Networks*, and *IEEE Transactions on Parallel and Distributed Systems*. He has served as General or Technical Program Chair and Technical Program Committee member of numerous IEEE and ACM conferences. He is a member of IEEE TCCC and TCPP Executive Committees.

LUCIANO LENZINI ([l.lenzini@iet.unipi.it](mailto:l.lenzini@iet.unipi.it)) holds a degree in physics from the University of Pisa, Italy. He joined CNUCE, an institute of the Italian National Research Council (CNR), in 1970. In 1994 he joined the Department of Information Engineering of the University of Pisa as a full professor. His current research interests include the design and performance evaluation of MAC protocols for wireless networks and QoS provision in integrated and differentiated services networks. He is currently on the Editorial Boards of *Computer Networks* and the *Journal of Communications and Networks*. He served as chairman of the 1992 IEEE Workshop on Metropolitan Area Networks and the 2002 European Wireless conference. He served as guest editor of the *IEEE Journal on Selected Areas in Communications* Special Issue on Analysis and Synthesis of MAC Protocols and the *ACM/Kluwer Wireless Networks* Special Issue on the best papers of EW 2002. He has directed several national and international projects in the area of computer networking.

MARCO CONTI ([Marco.Conti@iit.cnr.it](mailto:Marco.Conti@iit.cnr.it)) is a research director at IIT-CNR. He has published more than 180 research papers and two books: *Metropolitan Area Networks* (Springer, 1997) and *Mobile Ad Hoc Networking* (IEEE-Wiley, 2004). He has served as TPC chair of several conferences, including, IFIP-TC6 Networking 2002, IEEE WoWMoM 2005 and PerCom 2006, and ACM MobiHoc 2006. He is Associate Editor of *Pervasive and Mobile Computing* (Elsevier), and Area Editor for *IEEE Transactions on Mobile Computing and Ad Hoc Networks*.